



# Rigid PVCu Building Products



**Fig 1**



**Fig 2**

Rigid PVCu Fascia and Soffit Board cladding is one option offered as a realistic alternative to timber to relieve the burden of painting and general maintenance

This product is produced by using the traditional method of extrusion which is used for all window and door profiles and for a wide variety of building components

With reasonable care the materials will give trouble-free service for a minimum of twenty years. The co-extruded products are not adversely affected by normal atmospheric pollutants common acids or alkalis

We offer the rigid profiles in our unique brilliant white colour with a 10 year manufactures warrantee. This product is also available in one of the Decoroc colour ranges by special request and minimum quantity order

Fig1 shows the Rigid Fascia & Soffit fixing onto existing fascia boards. It is not recommended to fix any PVCu Fascia board directly onto the rafter ends as this does not achieve the best fixing for the Guttering, so in a replacement scenario an exterior best plywood is fixed, then cladded in the normal way with one of our PVCu products

Fig 2 shows one option of ventilation to the roof space, which is necessary on both replacement and cladding methods to allow the wood to breath

TYPICAL APPLICATIONS

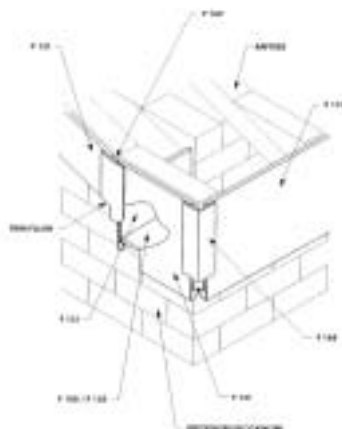

**Fig 3**

Our wide range of products adapt to most building structures and fig3 shows the Barge board meeting the eaves detail